



PROJECT: _____
 LOCATION: _____
 ITEM#: _____
 QUANTITY: _____

COMPETITOR SERIES®



C-CO1-NG



C-CO2-NG

CONVECTION OVENS

- Stainless steel exterior and enamel interior and coved corners for easy cleaning
- 50/50 dependent doors with double pane thermal tempered glass
- Size accommodates (5) 18" X 26" standard full-size baking pans left to right or front to back
- Solid state digital controller with hold cooking temperature feature
- Temperature range: 150°F to 500°F
- Interior oven light(s) standard
- 46,000 BTU's per oven
- Dual speed-fan with an adjustable cooling mode (5) nickel plated oven racks on 13-position rack guides
- Fan delay switch when doors are opened
- Electronic spark ignition with an automatic pilot system Safety shut off switch
- 3/4" NPT rear gas connection and regulator
- Natural or Propane models available
- Nema 5-15 plug for controller
- Migali Industries® Protection Plan: 1 Year Parts & Labor Warranty

MODEL	BURNERS	GAS SPECS	SHELVES	RACK GUIDES	VOLTS/ HZ/P	TOTAL BTU	BTU PER BURNER	INTAKE-TUBE PRESSURE (IN W.C.)	AMPS	DIMENSIONS W X D X H (INCHES)*	INTERIOR DIMENSIONS W X D X H (INCHES)*	PACKAGING DIMENSIONS W X D X H (INCHES)	WEIGHT	PACKAGED WEIGHT
C-CO1-NG	2	NG	5	13	115/60/1	46,000	23,000	5	8.5	38 1/5 x 48 3/5 x 59 2/5	29 x 31 1/2 x 24	34 x 37 x 30	370 lbs.	520 lbs.
C-CO2-NG	4	NG	10	26	115/60/1	92,000	23,000	10	8.5	38 1/5 x 48 3/5 x 69	29 x 31 1/2 x 48	34 x 37 x 55	740 lbs.	1045 lbs.

*MIGALI RESERVES THE RIGHT TO CHANGE SPECIFICATIONS WITHOUT NOTICE



TOLL FREE: 800.852.5292
 WEB: www.migali.com



Conforms to ANSI STD Z83
 11a-2009 (2011), NSF/ANSI STD 4
 & CSA STD 1-8b-2009(2011)

DIMENSIONAL DRAWINGS

C-CO1-NG

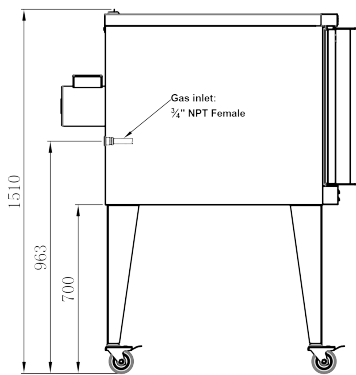
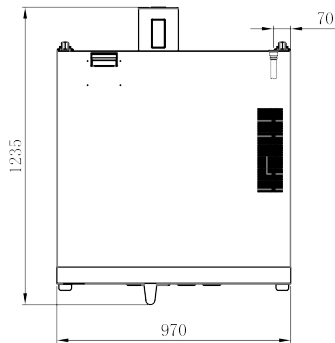
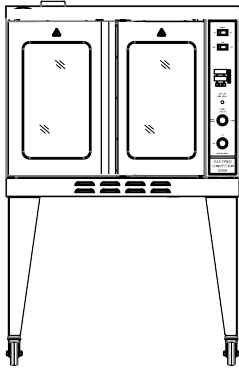

SIDE VIEW

C-CO2-NG

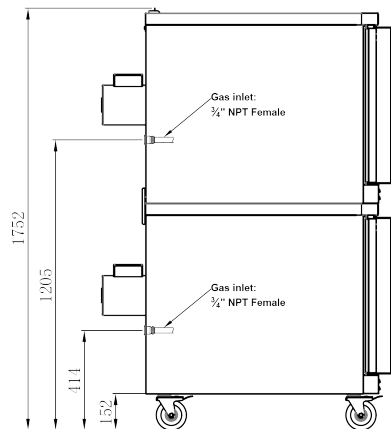
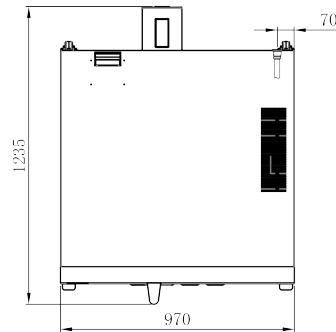
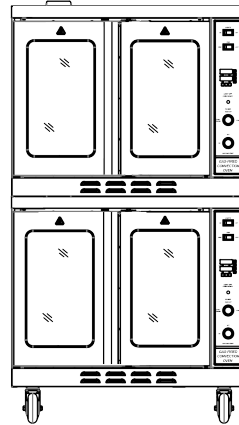

SIDE VIEW



MIGALI® REMAINS AN AMERICAN FAMILY COMPANY SINCE 1955